

FXairguns MADE IN SWEDEN

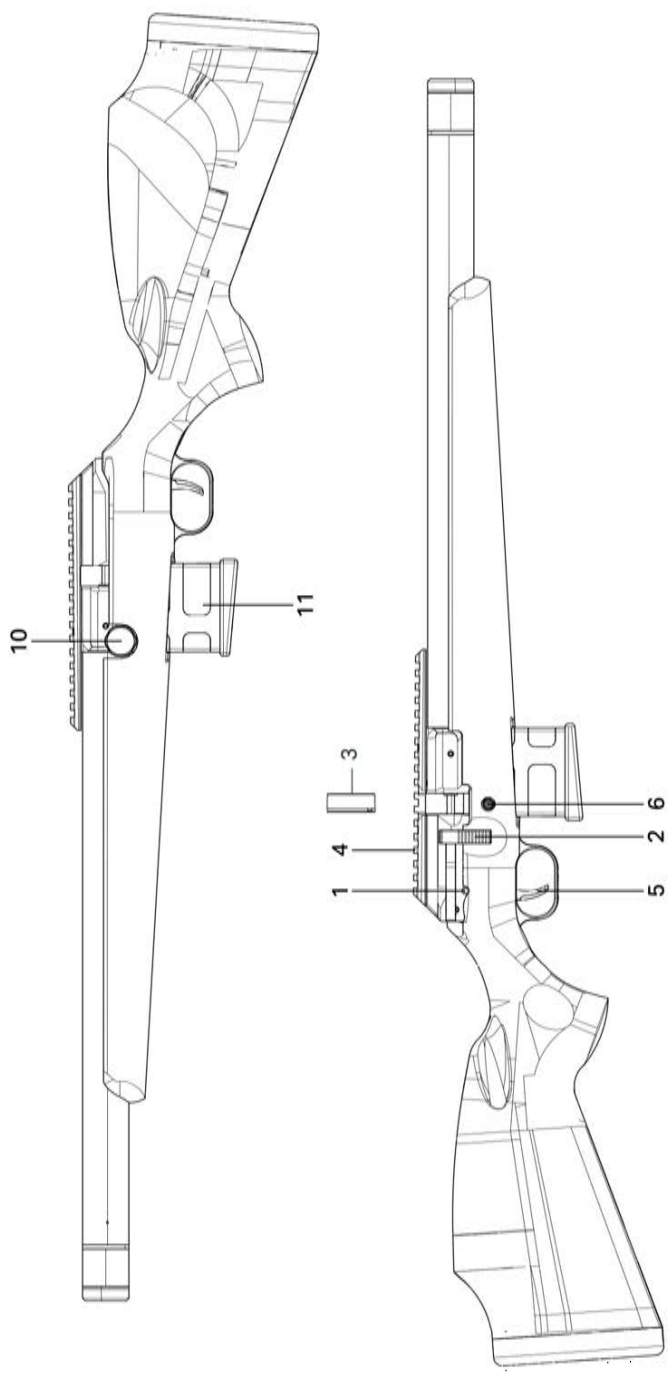

OWNER'S MANUAL FX DRS MKII

FX DRS MKII CLASSIC



- 1 Safety
- 2 Sidelever
- 3 Magazine
- 4 Optics Rail
- 5 Trigger
- 6 Charging Inlet
- 10 Pressure Gauge
- 11 Plenum

FX DRS MKII TACTICAL

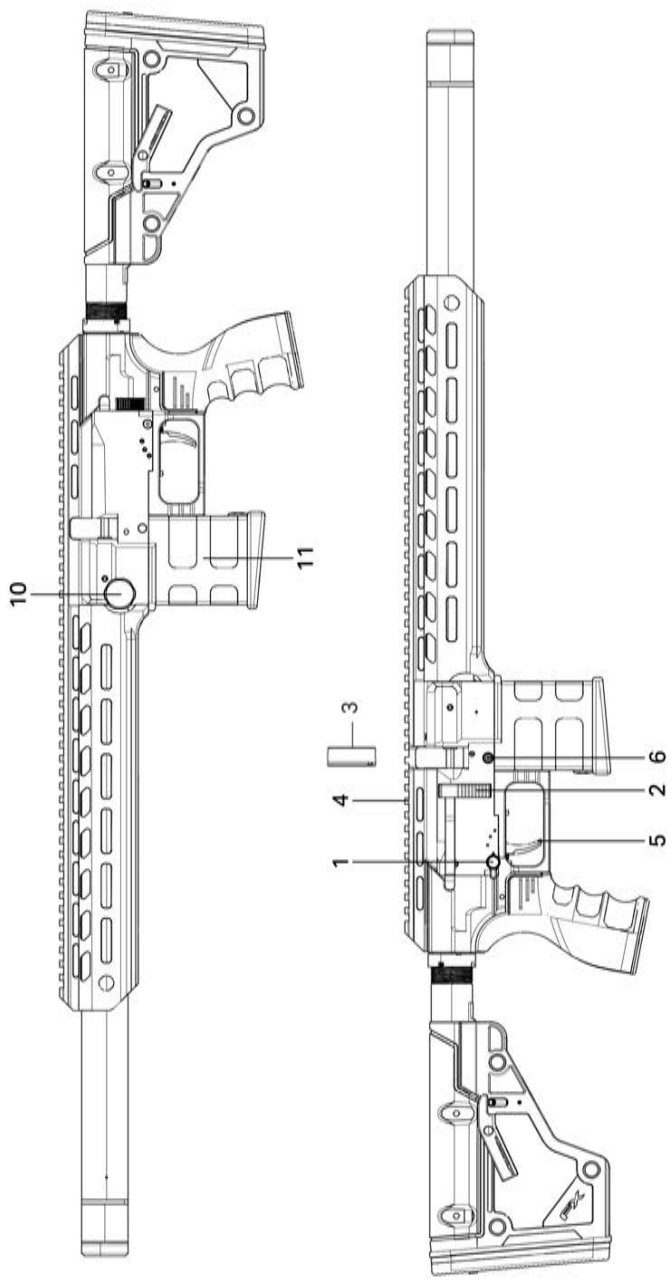

- 1 Safety
- 2 Sidelever
- 3 Magazine
- 4 Optics Rail
- 5 Trigger
- 6 Charging Inlet
- 10 Pressure Gauge
- 11 Plenum

FX DRS MKII TACTICAL BOTTLE VERSION

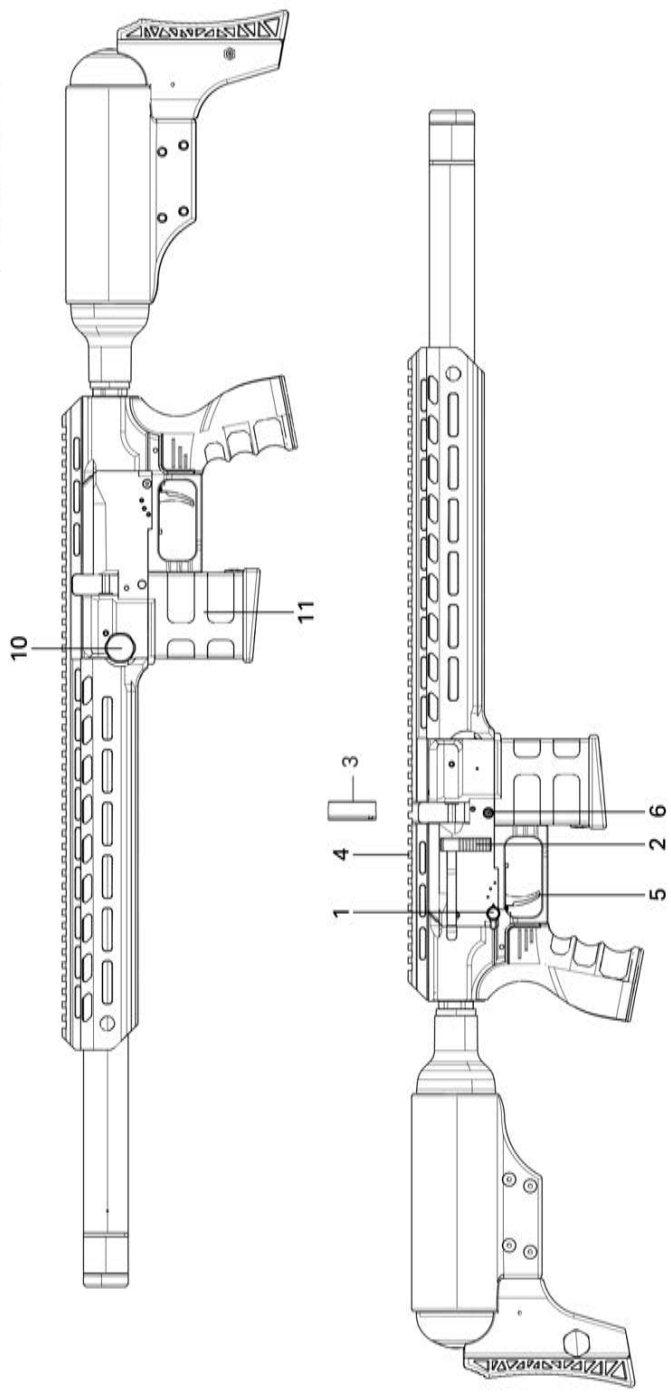

- 1 Safety
- 2 Sidelever
- 3 Magazine
- 4 Optics Rail
- 5 Trigger
- 6 Charging Inlet
- 10 Pressure Gauge
- 11 Plenum

Welcome

Welcome to the FX family and Congratulations to your new high-end precision tool! Please read and follow this manual thoroughly. This manual covers the main features of the FX DRS System.



Page

1 Warnings	5
2 Safety Operations	5
3 Handling (cocking and uncocking)	6
4 Gear up	6
5 Pressurize	6
6 Load your magazine	8
7 Use your airgun	9
8 Adjustments	12
9 Miscellaneous	15

Warnings

- Never attempt to disassemble this rifle.
- Never fire the rifle when it is empty of air or when air cylinder is removed.
- Never point the rifle at anyone or allow anyone to point a rifle at you.
- Treat every rifle as if it is loaded even if you know it is not loaded.
- Always carry the rifle so that the direction of the muzzle is under control, even if you stumble.
- Always be sure of your target and what lies behind it before firing your rifle.
- Never leave a loaded rifle unattended.
- Beware of targets that tend to cause ricochets.
- It is recommended that eye protection is worn.
- Always use caution when operating this rifle.
- Learn and obey the laws in your location.
- Be responsible in your use of this rifle.
- Never fill the rifle with anything else other than regular air.
- Never ever fire the rifle below set regulator pressure.
- If equipped with a carbon-fiber air tank: inspect according to the instructions on the tank.
- Never leave the rifle with ammunition in the bore/barrel.
- Do not attempt to remove or disassemble the barrel system (separate manual).
- Barrel runs thru a pressurized tube and faulty dismantling can cause serious damage.
- Failure to obey these Instructions could result in personal injury or damage to the gun!



Safety Operations

Safety lever is located on the right side of the rifle (1)

Safe: Not possible to fire the gun.

Fire: You are able to fire the gun.

Keep the gun in safe mode when you do not intend to fire.

Note: Never point the rifle at anyone even if it is set to "safe".

3 Handling

3.1 Cocking the rifle

Prepare the rifle for use by learning how to operate the sidelever cocking system.

Pull the sidelever (2) rearwards, this engages the trigger and hammer simultaneously.

A distinguished click in the most rearward position is the indication of a successful cocking.

Move the sidelever forward and make sure it is completely closed, your gun is ready to be fired.

It is preferable to store the gun un-cocked, so next step is to learn how to un-cock.

3.2 Uncocking the rifle/inactivate trigger system

Pull the cocking lever (2) to its rear position, put the safety (1) to Fire.

Hold one hand on the cocking lever and then with the other hand you squeeze the trigger (5) and simultaneously gently move the cocking lever forward.

This will release the trigger and hammer-spring tension. For Left hand shooters.

4 Gear Up

4.1 Optics Mount (4)

The DRS system is equipped with a 11mm dovetail rail as base.

Picatinny style rail in different styles is available as editions and as accessory.

Mount your optics according to the optics manual but wait with zeroing until you have come to point 7.3. Zeroing.

5 Pressurize

5.1 Preparation

One quick connector pin probe style (MkIII) is supplied with the rifle, this can be attached to the most common charging sources on the market.

NOTICE – Attach the probe quick connector to the source and make sure it is secure. 2 seals (1) are included and attached to the connector.

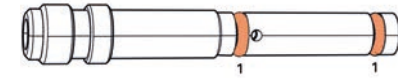

5.2 Pressurize

Max overall pressure in system: 230 BAR.

Max air reservoir pressure: See markings on air reservoir.

Close ventilation screw on the charging source. Push the fill probe into the charging hole (6)

Charge the rifle to wanted pressure without exceeding maximum pressure limit of air reservoir or main block.

You read the charging pressure of the main pressure gauge (10).

Also check the pressure on the charging source, they have in some case a more reliable gauge.

The gauges on the gun are indicators and might not be 100 % accurate.

When you are ready with the fill you drain/bleed hose pressure on the charging source and simply release the quick connector by pulling the probe out.

Recharge as soon as you come to the point when tank pressure (10) reaches regulator output pressure.

If the gun is completely empty when you start filling you might experience difficulties to get the gun to hold the air, you might notice it by air escaping thru the barrel.

This can be prevented by opening the sidelever/cocking the gun. This releases the pressure from the Hammer/hammer-spring on to the valve. As soon as the system takes on air you can uncock the rifle as explained in section 3.2.

WARNING – Only dry air should be used! Under no circumstances should Oxygen or any other gas be used to fill the air-tubes! This might result in serious injury or death!

6 Magazine

How to load the magazine (3)

Turn the lid-lock (1) to the position (open) where you can remove the lid (2).
Turn the pellet tray (3) counterclockwise until you hit the stop.

Put a pellet into the first position (4) head first while holding your finger under the hole to stop it, let go of the pellet tray as the pellet you inserted will lock and prevent the pellet tray from rotating.

Insert the rest of the pellets head first, make certain all the pellets fall in correctly into their slots (5).

Once the magazine has been filled, put the lid back into position and turn the lid-lock until it is the opposite position of the cutout (locked).

Our guns are tested and tuned in the factory for best possible performance and accuracy.

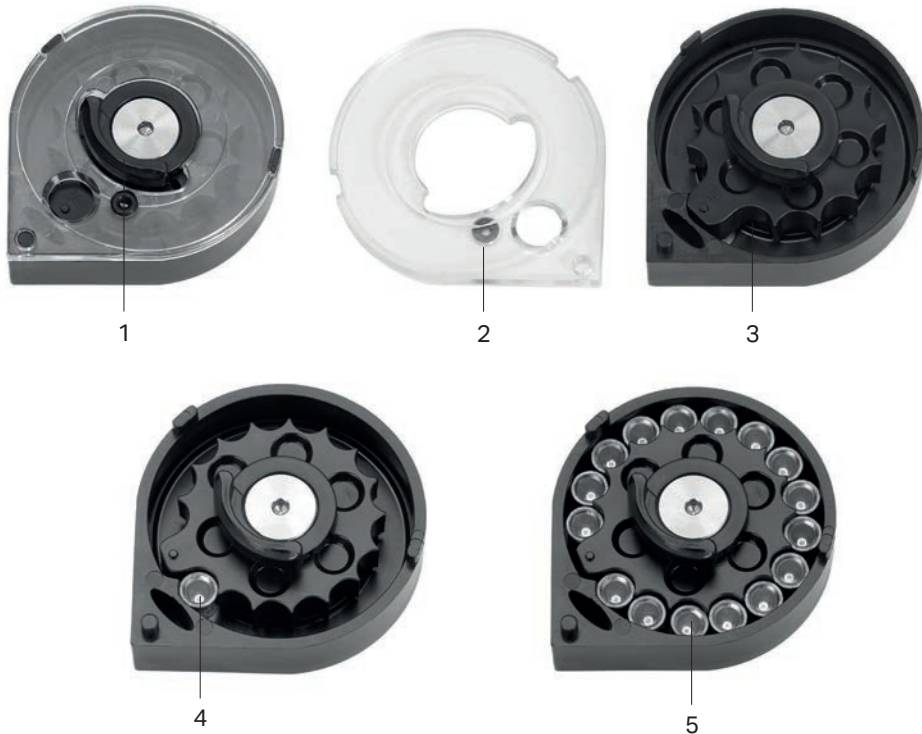

7 How to use

7.1 Inserting magazine

Set the safety (1) to "Safe" position.

Prepare the rifle for use by pulling rearward on the cocking lever (2) until it clicks in the rearward position.

The barrel breech has a protruding edge which match the slot in the magazine. Carefully insert the magazine in the magazine slot.

Press firmly to ensure the magazine is completely installed.

Closing the cocking lever will now load a pellet into the barrel and make the rifle cocked and ready for use.

Make sure that side lever is completely closed in the front position, failure to do so might result in damaged cocking mechanism. This kind of abuse is not covered by warranty. Be sure to keep the rifle pointed in a safe direction throughout this entire procedure.

NOTE – Each cocking enters a pellet into the barrel, if not fired for each repetition you will end up with more than one pellet/slug in the barrel. If this happens you will need help from a gun smith.

Do not remove ammunition in the barrel without proper know-how as you might damage barrel.

If you want to end your shooting session with half used magazine It's preferred that you fire the current round in your chamber and then remove the magazine to make sure you do not store the gun with ammunition in the barrel.

7.2 Removal of Magazine

Put the safety (1) in "Safe" position and then pull the cocking lever (2) rearwards.

Pull the magazine out of the slot. Un-cock the rifle (3.2) before putting it to the side or leave it with open sidelever.

7.3 Zeroing the scope

When you feel you have a grip of the overall function you can move on to dial in your scope with support from the scope manual.

7.4 Power Settings

The power setting for this gun is from the factory set to perform at its best but to get the best out of the specific ammunition you intend to use you might want to fine tune the setting of the gun.

Before you make any alternations, it is important that you write down the current setting so you always can go back to the factory settings.

7.5 Hammer-spring tension adjuster

The Hammer-spring tension might need adjustment if you need to tune the power and accuracy.

NOTE – The rifle must be un-cocked when you turn the adjuster.

High spring tension gives more power but uses more air.

NOTE – for best results the hammer tension needs to work in coordinated effort with the appropriate regulator pressure as described further in section 8.1.

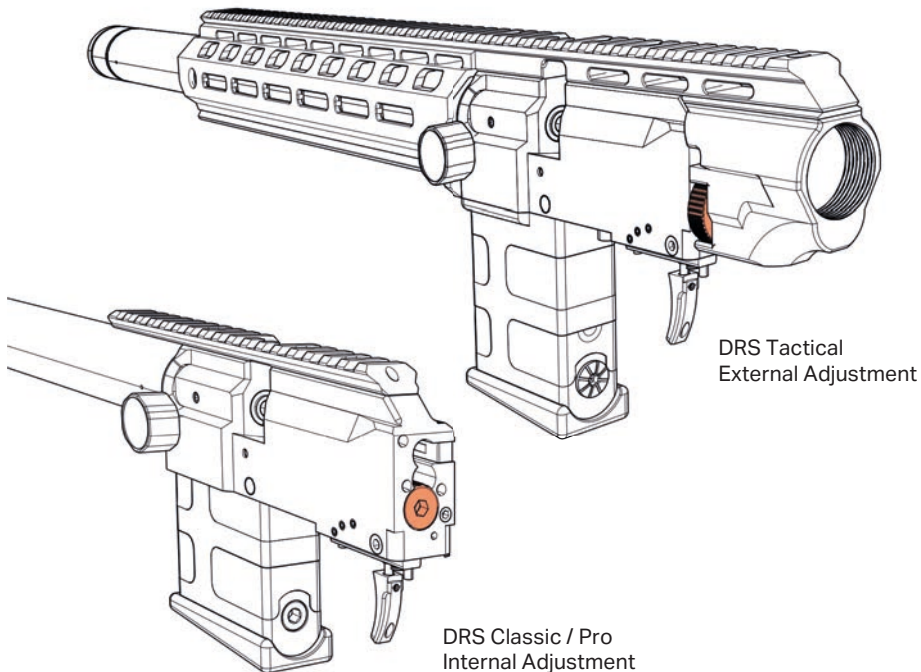

Notes for your own settings

Make note of the factory setting before you start tuning the rifl .

	Factory settings			
Regulator pressure				
Hammersping position				
Ammunition				
Chronograph reading				
Comments				

There is no magic formula on how to tune but there are some basic guidelines:

Higher power does not mean better accuracy.

Too much hammer spring tension combined with low regulator pressure might result in high air consumption.

Why would I want to alter current power settings?

- Lower power to achieve less penetration.
- Increase power for higher penetration or longer distance.
- Lower power to get less air consumption when shooting short distance.
- Fine tune for better accuracy (sweet spot).
- Change of ammunition.

8 Adjustments

8.1 Adjustable AMP Regulator

Note: Not all models are equipped with gauge (1) for reading the regulator pressure. If not, you will not be able to carry out this adjustment properly. However, there is a connection with a removable plug in the plenum where you can fit a gauge temporarily while you carry out the adjustment.

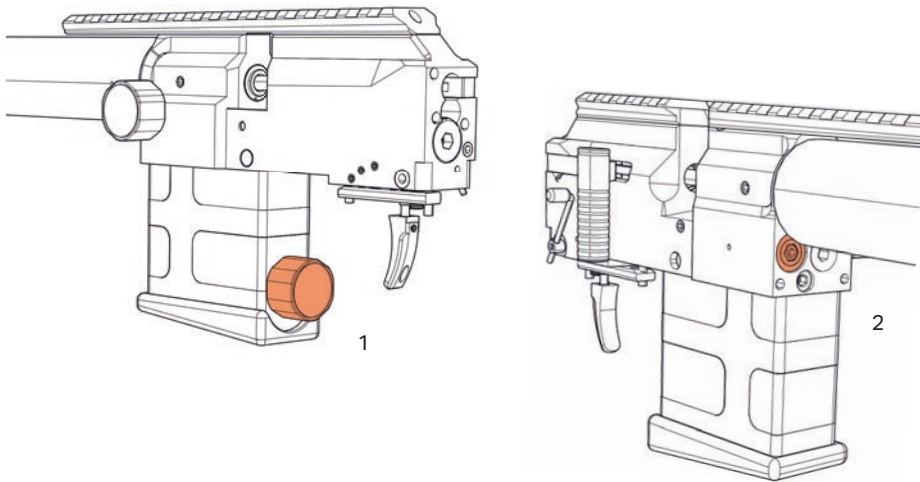

The regulator reduces the pressure and sets the output / working pressure for the rifle.

Tools required

2,5 mm hex key with ball end.

Normally you will want the regulator (2) set at the lowest possible pressure for the velocity you aim for.

To increase regulator pressure

Make sure you have more pressure in the tank than intended regulator pressure before starting this adjustment.

Gently adjust the regulator counterclockwise a quarter of a turn and check the pressure on gauge. Repeat until the wanted pressure has been reached.

To decrease regulator pressure

Make sure there is no ammunition in the bore before making any adjustments.

Gently adjust the regulator clockwise a quarter of a turn, fire one empty shots in a safe direction until pressure stops dropping. Repeat this process until the intended pressure has been reached.

NOTICE – Make sure your rifle does not have ammunition in the bore/barrel before dry firing.

NOTICE – NEVER adjust the regulator above 180bar as damage to the system may occur and will void your warranty!

WARNING – NEVER use the gun below the set regulator pressure as damage to the system may occur and will void your warranty!



8.2 Trigger (5) Trigger position

Trigger blade (3) can be adjusted in height and rotated to set the blade in an angle.

Loosen screw (2) to adjust height or angle, tighten when you are satisfied. For liability reasons, we cannot give instructions on trigger weight or travel adjustments.

Following information is a reference showing adjustment screws and what aspect of the trigger they adjust.

The 2nd stage Adjustment (1) is the second stage tension adjuster.

The 1st stage Length Adjustment (4) controls the travel/1st stage length of pull.

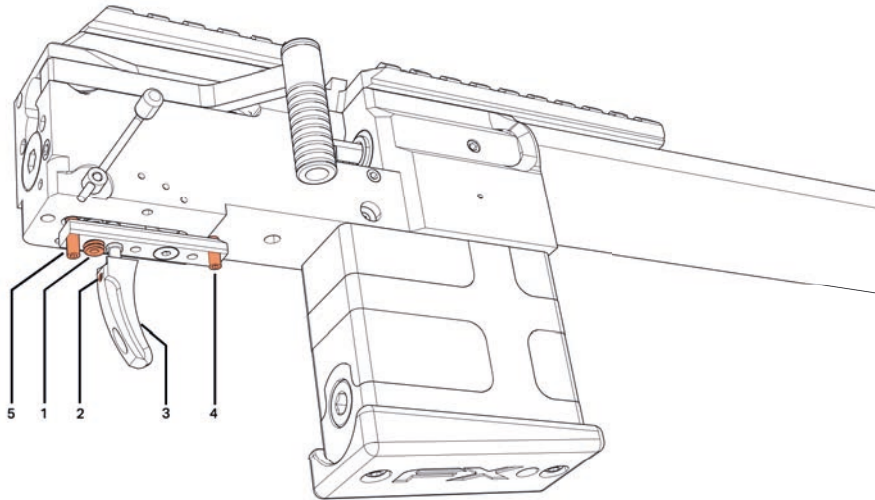

WARNING – Adjustment to the 1st or 2nd stage might cause safety malfunction. Adjustments to 1st or 2nd stage might void your warranty.

Adjustments to one screw may impact the function or other aspects of the trigger-function.

Proper tuning requires the know-how of what one adjustment does in relation to another and should be performed by a trained specialist.

Always make adjustment with unloaded rifle and empty barrel. Always point the rifle in a safe direction while adjusting the trigger.

Never rely on the trigger or safety when pointing your rifle at any target.

To ensure safety and reliability make sure you test thoroughly before you use the rifle. Safety must be checked and adjusted (5) after doing any adjustments on the trigger settings.

9 Miscellaneous

9.1 Warranty

All FX Airguns carry a Three-Year Warranty against faulty workmanship and defective materials. If it becomes necessary, first contact the dealer from which you purchased the gun. If the rifle is determined to have a defect within the warranty period, contact the warranty center to arrange service. The warranty guarantee does not cover any damage caused by tampering with the rifle or abuse. This rifle should only be disassembled by factory-authorized repairmen.

9.2 Maintenance

Keep the rifle clean.

Steel parts will benefit from occasional oil treatment preventing them from corrosion.

We recommend the use of cleaning pellets occasionally or if there is a sudden change in accuracy.

WARNING Never use chemicals or water to clean the rifle.

9.3 Storage

Store dry and dark if possible.

Preferable stored pressurized just above regulator pressure to max pressure.

WARNING High humidity might cause corrosion if not treated correctly. Keep away from sunlight as this might damage o-rings and anodizing. Never store the rifle with loaded magazine.

Keep out of reach for children or unauthorized persons.



FXairguns MADE IN SWEDEN
www.fxairguns.com